

Instruction Guide

GRILLE KIT

RMG-200A, RSH-462

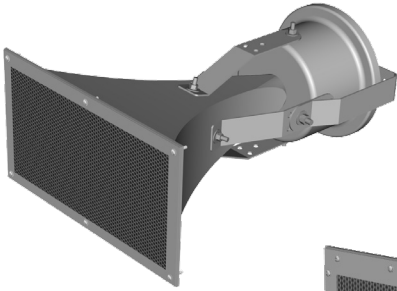

RMG-200A
Grille Kit

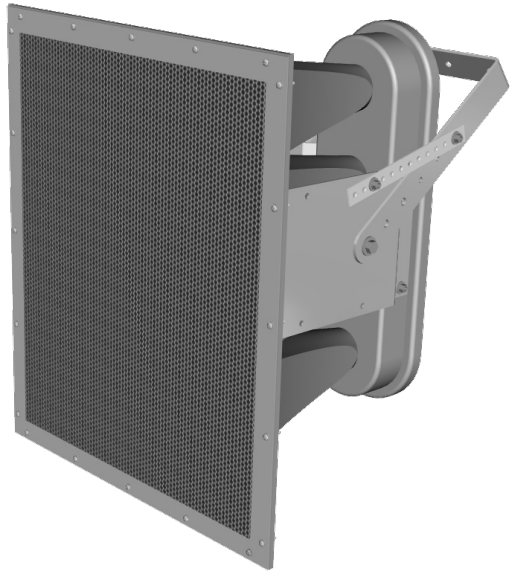

RSH-462
Grille Kit

ABOUT INSTALLATION

The wiring and installation of the loudspeakers is not discussed in this guide. Please refer to the RMG-200A or RSH-462 Installation and Operation Manual for complete information.

TOOLS / MATERIALS NEEDED:

- RMG-200A or RSH-462 Loudspeaker (not provided with this kit)
- Adjustable speed drill with 3mm and 6mm or 1/8" and 1/4" drill bits (for pilot and finish holes), Phillips head screwdriver, 3/8" socket / wrench
- Masking tape, grease pencil, spring-loaded center punch
- Grille Kit: Grille and hardware

Hardware	RMG-200A kit	RSH-462 kit
10-24 SS Hex Nuts	6	20
10-24 x1" SS Phillips Screws	6	20
#10 SS Flat Washers	12	40
#10 SS Lock Nuts	6	20

INSTALLATION

Note: It will be easier to drill the horn if the loudspeaker is not mounted. Secure the loudspeaker to a stable work surface.

Align the grille with the front edge of the horn and tape into place. (The RMG-200A already has corner holes - align before taping). See **Figure 1**.

Mark all holes with a grease pencil and remove tape and grille.

Hint: Use a spring-loaded center punch to mark the center of the hole before drilling to reduce the chance of bit slippage. Do not use a hammer and punch to mark the horn - the horn may crack with excessive pressure.



CAUTION: Do not drill the holes while the grille is taped to the loudspeaker. The side of the drill bit may chip or crack the powder coat, voiding the warranty. Chips or cracks in the powder coat may lead to corrosion and/or rusting of the grille.

Using the smaller drill bit, and a slow speed, drill a pilot hole in the center of each mark.



CAUTION: The fiberglass is smooth and care should be taken to avoid bit slippage or fracture of the horn edge.

Align the grille on the horn to ensure pilot holes are correct. Remove grille and using the larger bit, redrill all holes.

Place grille on the horn and attach as shown in **Figure 2**. Complete assembly is shown in **Figure 3**.

Mount the loudspeaker. Refer to the appropriate installation guide for your model. Current installation guides are available from the Community website: www.communitypro.com.



WARNING: Be careful not to over- or under-tighten fasteners. Sufficient torque must be applied to ensure a secure assembly. Over-tightening can lead to damaged fasteners or cracked fiberglass. Either scenario can lead to risk of assembly separation leading to injury, death, or property damage.



CAUTION: Installation of the loudspeakers should only be performed by trained and qualified personnel. It is strongly recommended that a licensed and certified professional structural engineer approve the mounting design. Severe injury and/or loss of life may occur if this product is improperly installed.

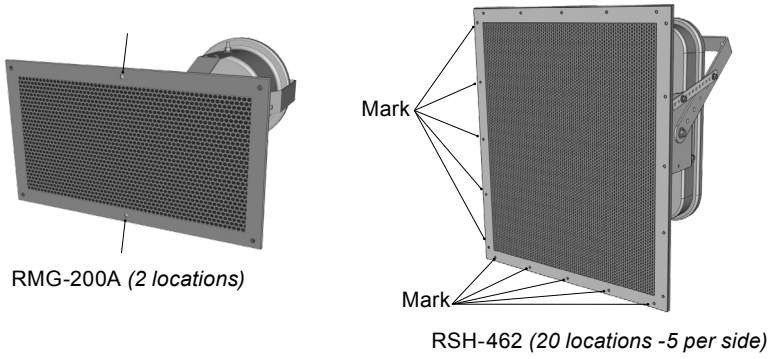

Figure 1. Place grille on horn, align edges, and mark holes

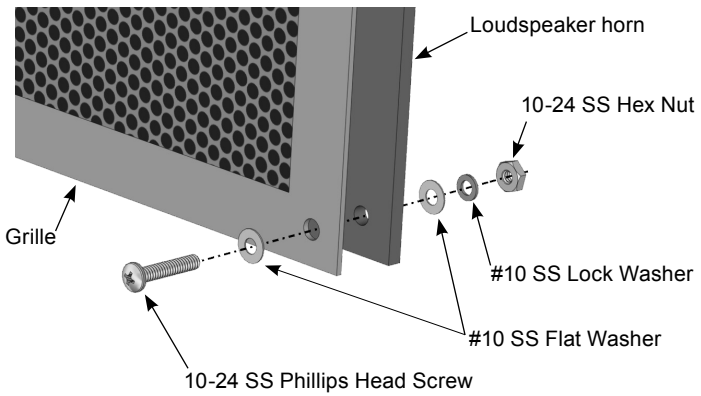

Figure 2. Grille installation (*RMG-200A* shown)

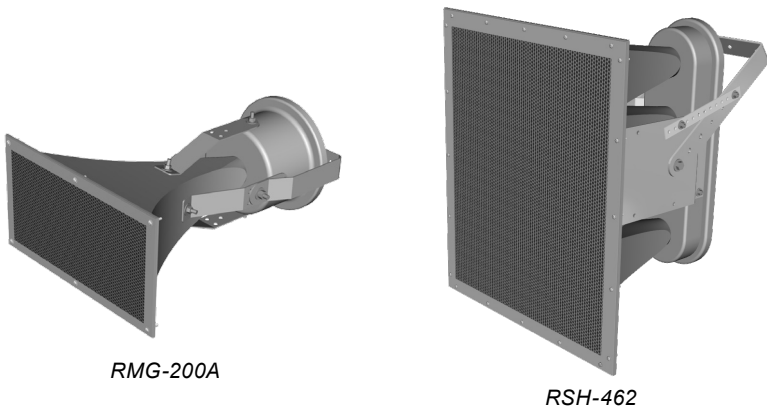

Figure 3. Loudspeakers with grilles installed

WARRANTY INFORMATION

TRANSFERABLE WARRANTY "(LIMITED)" VALID IN THE USA ONLY

The R-Series Loudspeaker Systems are designed and backed by Community Professional Loudspeakers. For complete warranty information within the USA please visit www.communitypro.com/warranty. Please call 610-876-3400 to locate your nearest Authorized Field Service Station. For Factory Service call 610-876-3400. You must obtain a Return Authorization (R/A) number prior to returning your product for factory service.

WARRANTY INFORMATION FOR COUNTRIES OTHER THAN THE USA

To obtain specific warranty information and available service locations for countries other than the United States of America, contact the authorized Community Distributor for your specific country or region.

SHIPPING DAMAGE / CLAIMS

If the product is damaged during transit you must file a damage claim directly with the freight company. It's very important to contact the freight company as soon as possible after receiving your shipment, as most freight companies have a short time limit within which they will investigate claims. Be sure to save the carton and packing materials, as damage claims can be denied if these materials are not retained. If evidence of physical damage exists upon arrival, be cautious before signing the delivery acceptance receipt. Often, the fine print will waive your right to file a claim for damage or loss after you sign it. Make sure that the number of cartons shown on the freight documents have actually been delivered.

For a copy of the complete warranty statement, visit www.communitypro.com/warranty

Please register your product online at www.communitypro.com/productregistration

***Note:** Every effort has been made to insure that the information contained in this manual was complete and accurate at the time of printing. However, due to ongoing technical advances, changes or modifications may have occurred that are not covered in this manual. Visit Community at <http://www.communitypro.com> for the latest version of this document and the most recent product information.*