

COMMUNITY I SERIES

IV6-LAF-PBB

for **Indoor**
IV6 Modular Vertical Arrays

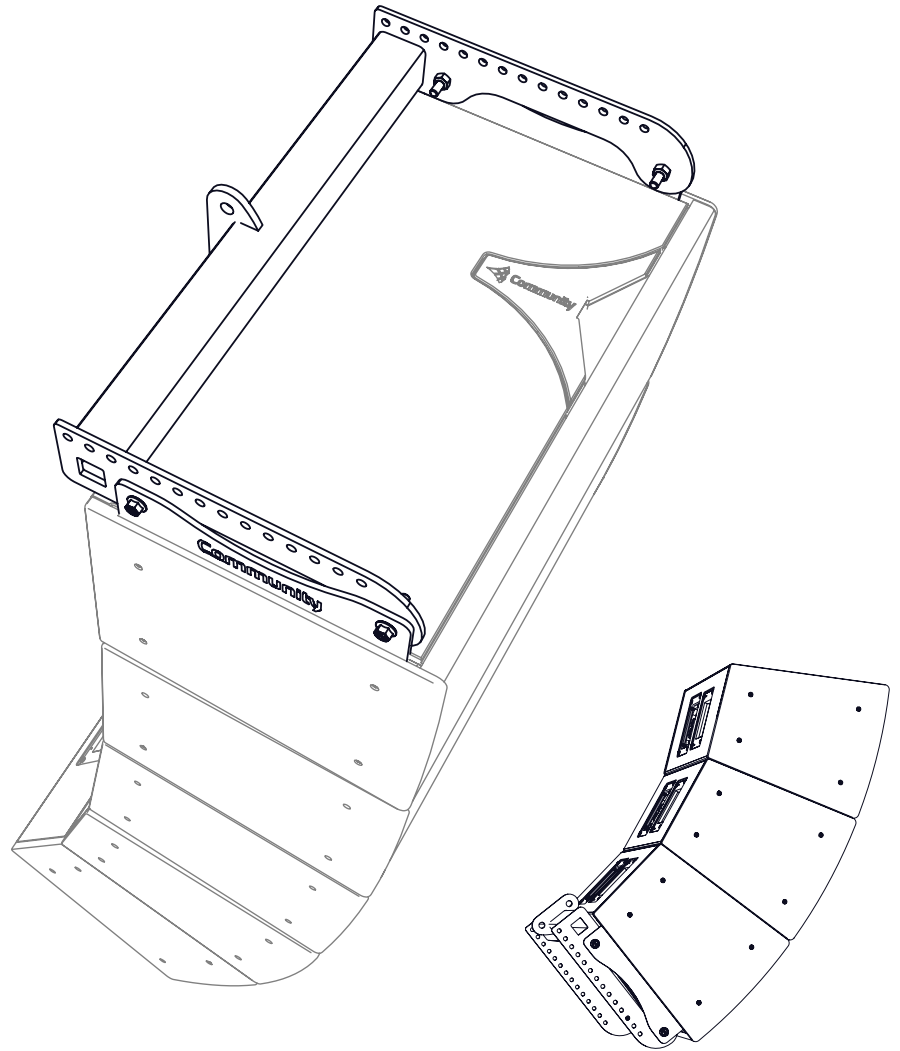

IV6 Light Array Frame / Pull Back Bar
(shown with loudspeakers)

The IV6 Rigging Frames, Accessories and Safety Guide (a complete set of instructions including all of the IV6 indoor rigging frames, accessories and information) is available on the Biamp website <[here](#)>

IMPORTANT: *The Instructions, and illustrations in this manual are to be used with INDOOR IV6 cabinets/models only. The IV6-WR loudspeakers differ in width and mounting points and will NOT fit this array frame. Contact Biamp's [Loudspeaker Support Group](#) for information regarding mounting options for WR (outdoor) IV6 loudspeakers.*

IMPORTANT SAFETY INSTRUCTIONS

Always follow these basic safety precautions when using or installing I SERIES loudspeakers and accessories:

- Read these instructions prior to assembly, and keep for reference.
- Heed all warnings.
- Follow all instructions, particularly those pertaining to rigging, mounting, hanging and electrical connections.
- Do not use this apparatus near water (indoor models only).
- Clean only with dry cloth.
- Do not block any ventilation openings. Install in accordance with the manufacturer's instruction.
- Do not install near any heat sources such as radiators, heat registers, stoves, or other apparatus (including amplifiers) that produce heat.
- Only use attachments and accessories that are specified and approved by the manufacturer.

Refer all servicing to qualified service personnel. Servicing is required when the apparatus has been damaged in any way, does not operate normally, or has been dropped.

The terms caution, warning, and danger may be used in this manual to alert the reader to important safety considerations. If you have any questions or do not understand the meaning of these terms, do not proceed with installation. Contact your local dealer, distributor, or call Biamp directly for assistance. These terms are defined as:



CAUTION: describes an operating condition or user action that may expose the equipment or user to potential damage or danger.



WARNING: describes an operating condition or user action that will likely cause damage to the equipment or injury to the user or to others in the vicinity.



DANGER: describes an operating condition or user action that will immediately damage the equipment and/or be extremely dangerous or life threatening to the user or to others in the vicinity.

RIGGING and ELECTRICAL SAFETY



IMPORTANT: IV6 loudspeakers are designed and intended to be mounted to differing indoor building surfaces using a variety of rigging hardware, means and methods. Installation of loudspeakers should only be performed by trained and qualified personnel. It is strongly recommended that a licensed and certified professional structural engineer approve the mounting plan. Severe injury and/or loss of life, and property damage may occur if these products are improperly installed.



DANGER: All rigging fittings must be fully tightened and secured. Any missing fasteners will compromise the structural integrity of the enclosure and constitute a safety hazard. Do not suspend any loudspeakers unless all fasteners are securely in place!



DANGER: It is possible to experience severe electrical shock from a power amplifier. Always make sure that all power amplifiers are in the "OFF" position and unplugged from an AC Mains supply before performing electrical work.



CAUTION: Installation of I SERIES loudspeakers should only be performed by trained and qualified personnel. It is strongly recommended that a licensed and certified professional structural engineer approve the mounting. Severe injury and/or loss of life may occur if this product is improperly installed.

UNPACKING / INSPECTION

Community I SERIES rigging accessories are engineered and manufactured to be rugged and they are carefully packed in sturdy cartons. However, it is recommended to thoroughly inspect each unit after it has been removed from the packaging, as damage could occur during shipping.

Please note that once the shipment has left your dealer or the Biamp factory, the responsibility for damage is always borne by the freight company. If damage has occurred during shipping, you must file a claim directly with the freight company. It's very important to contact the freight company as soon as possible after receiving your shipment, as most freight companies have a short time limit within which they will investigate claims. Make sure to save the carton and the packing material, as most claims will be denied if these materials are not retained. Your Biamp dealer and the factory will try to help in any way they can, but it is the responsibility of the party receiving the shipment to file the damage claim.

It is always a good idea to retain the carton and packing materials, if possible, in the event that the unit may need to be returned to your dealer or distributor for repair in the future.



WARNING: I SERIES rigging fittings are rated at Working Load Limits (WLL) with a 10:1 safety margin. All mounting provisions on the IV6 cabinets meet or exceed the 10:1 safety margin to support the cabinet when used with the specified mounting brackets, either from Biamp or designated 3rd party vendors.

Disregarding and/or exceeding the safe working load limits could result in injury or death!

TOOLS NEEDED FOR ASSEMBLY:

- Metric socket and ratchet set
- Metric wrench set
- Phillips screwdriver

SYSTEM DESIGN

All system designers incorporating IV6 arrays are encouraged to use EASE® Focus 3 (EF3) from AFMG to model the array(s). A link to the latest version is available on our website. Download the latest IV6 GLL file to utilize our customized VenuePolar™ module. Our exclusive VenuePolar module makes building the array, optimizing the coverage, and determining the loads and load safety factor easy. Once built, the system report option creates a convenient PDF printout documenting the array components, the optimization/attenuation settings for the loudspeakers and simplifies ordering.

The custom Rigging Safety Calculator (RiSC) (located in the VenuePolar module "Loads" tab) automatically populates and updates in real-time as an array is built and aimed. Refer to the "IV6 System Design and Installation Manual" for instructions and explanations about system design with our custom VenuePolar module in EASE® Focus 3 and array assembly.

EASE® and AFMG® are registered trademarks of AFMG Technologies GmbH.

ACCEPTABLE MOUNTING POINT LOADING

Use the "Loads" tab to ensure the rigging's Safe Working Load (SWL) and required Safety Factor are not exceeded. Additional RiSC information is available in the "IV6 Rigging Frames, Accessories and Safety Guide". The system should be modeled in EF3 prior to ordering, and the system design report generated should also be utilized when installing / assembling the array. The software and system information is available on the website (search for IV6). Use the QR code in the upper right corner of this page for a link to the IV6 downloads page.

For sub-behind applications use the "IV6 Sub Behind Hang Point Calculator" to ensure proper deployment of the IV6-SB-AF bracket. It is available from the IV6 "Accessories" section on the website.

INSTALLATION AND ASSEMBLY TIPS

- Test all cabinets before hanging
- Arrange cabinets in the order that they will hang, and loosely attach appropriate splay brackets to the top of each cabinet
- Preset attenuation settings per the EASE® Focus 3 model on each cabinet
- If using the IV6-SB-AF, adjust the carriage on the array frame to the suggested pin setting before attaching the loudspeakers
- Orient cabinets so the horns align along the length of the array - this also aligns the input panels for easy wiring
- Leave splay bracket connections slightly loose until all cabinet connections are made, then tighten evenly



IMPORTANT: The hex head Grade 10.9 rigging bolts that are used to secure the splay brackets must also fill any unused holes (at the bottom of a flown array or at the top and bottom of a ground stack) to seal the enclosure from air leaks. If those threaded holes are not sealed, air leaks will occur in the enclosure that will compromise the low-frequency performance with distortion, reduced output, and premature driver failure.



bia.mp/IV6_pubs

Safety Cable

The safety cable and associated hardware are not included. Consult all applicable codes for your application. Confer with a structural engineer for the appropriate cable/hardware for the load, application and locale. If required, the safety cable must be secured to a suitable load-bearing point separate from the array mounting point, with as little slack as possible, so as not to develop undue kinetic force if the primary array mount were to fail.

Light Array Frame (IV6-LAF-PBB)

When required, a secondary safety cable can be attached to an unused hole(s) on the LAF.

GlidePoint™ Array Frame (IV6-GP-AF)

A secondary safety cable mounting point is available from [PolarFocus](http://PolarFocus.com). Part number: RLP-X2-1800

Sub Behind Array Frame (IV6-SB-AF)

Contact PolarFocus, for a quote for a custom secondary attachment point(s) required for your particular application.

LIGHT ARRAY FRAME / PULLBACK BAR

APPLICATION: Suspend a small indoor loudspeaker array of up to ten (10) IV6-1122 elements* or provide pullback point for a larger curved array.

Before Assembly: Record the Pin# from EASE® Focus 3 (EF3) to define the lift points for the array. Refer to the Pinpoint Reference on the next page.

ASSEMBLY

1. If the frame will be at the top of an array, position the S1 splay brackets against the array frame with the Community name facing out. Loosely attach the brackets with the flanged Grade 10.9 bolts and nuts.

Note: If the frame is being used as a pullback bar at the bottom of the array, reverse the plates, turning the Community art inward.

2. Attach the splay bracket to the IV6 cabinet as shown in the array assembly instructions. Leave all connections slightly loose until all frame-to-cabinet bolts are started, then tighten the hardware.

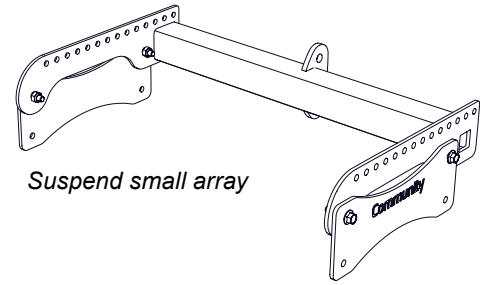

Suspend small array

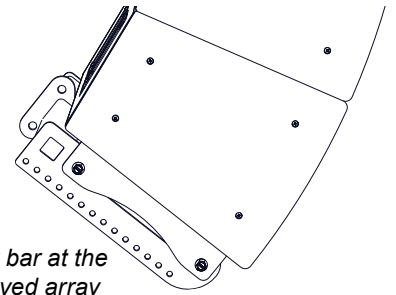

Use as pullback bar at the bottom of a curved array

Parts:

LAF-PBB

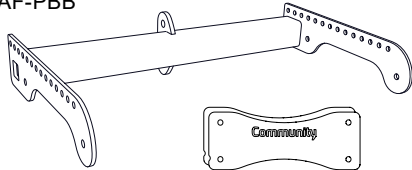

S1 with Logo

IV6-LAF-PBB

LAF-PBB: Light Array Frame (1)

S1 w/ Logo: Splay brackets w/wordmark (2)

Hardware:

Qty	Code	Description
4	HHB-F	Grade 10.9 Flanged Hex Head Bolts
4	HN-F	Flanged Nuts

Kit Weight: 23 lbs (10.4 kg)

Working Load Limit: (10:1 safety factor)

As a **Light Array Frame:** 850 lbs (385.6 kg)

As a **Pullback Bar:** 1600 lbs (725.7 kg) at the cable attachment tab

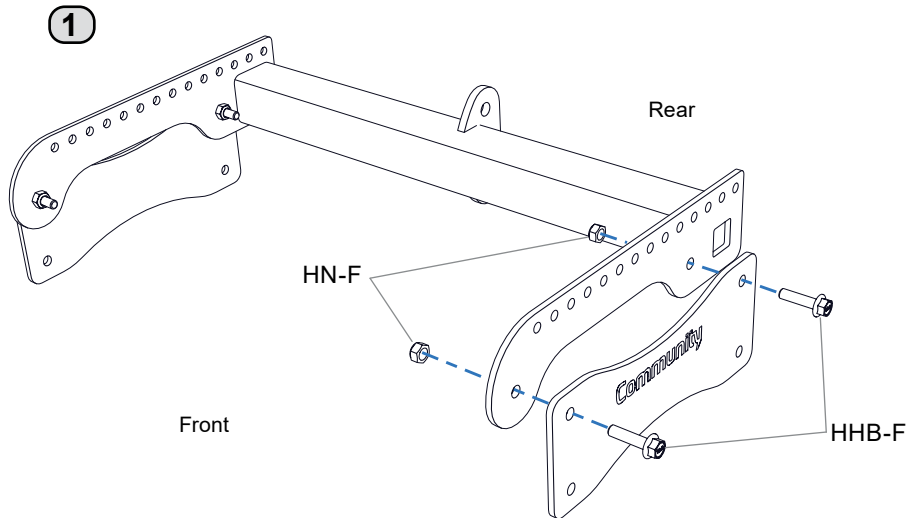

LAF-1. When used at the top of an array, use the Grade 10.9 hardware, loosely connect the splay brackets to the array frame with "Community" facing out



IMPORTANT: Leave bracket hardware slightly loose until the cabinet is attached to the brackets. This allows cabinet to fit between the brackets easily. After all eight (8) bolts are started, fully tighten bolts. Do not place under load until connections are tight!

***NOTE:** Additional loudspeakers above the suggested maximum may be added to the array when using an IV6-LAF-PBB (pull back bar) to share the load. Please refer to the "Loads" tab in EF3 to ensure that the desired safety factor is not exceeded.

LIGHT ARRAY FRAME / PULLBACK BAR (CONTINUED)

PINPOINT REFERENCE

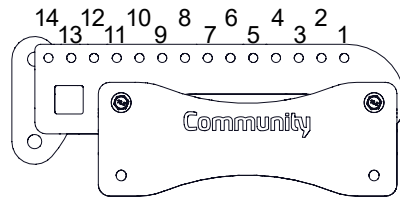

Pinpoint reference for suspension
(Pin Number from EF3)

USED AS LIGHT ARRAY FRAME

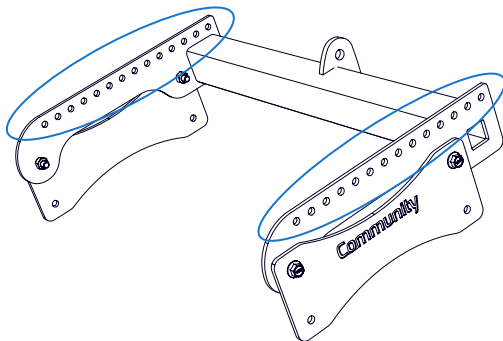

Connect suspension hardware to upper holes
along the side rails (circled)
Use defined Pin# from EF3

USED AS PULLBACK BAR

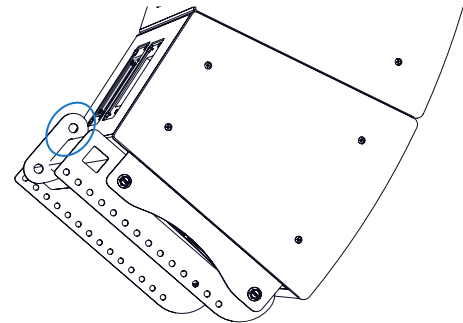

Connect pullback cable hardware to the upper hole of
the center tab (circled) welded to the square tube

TECHNICAL DRAWING

IV6-LAF-PBB

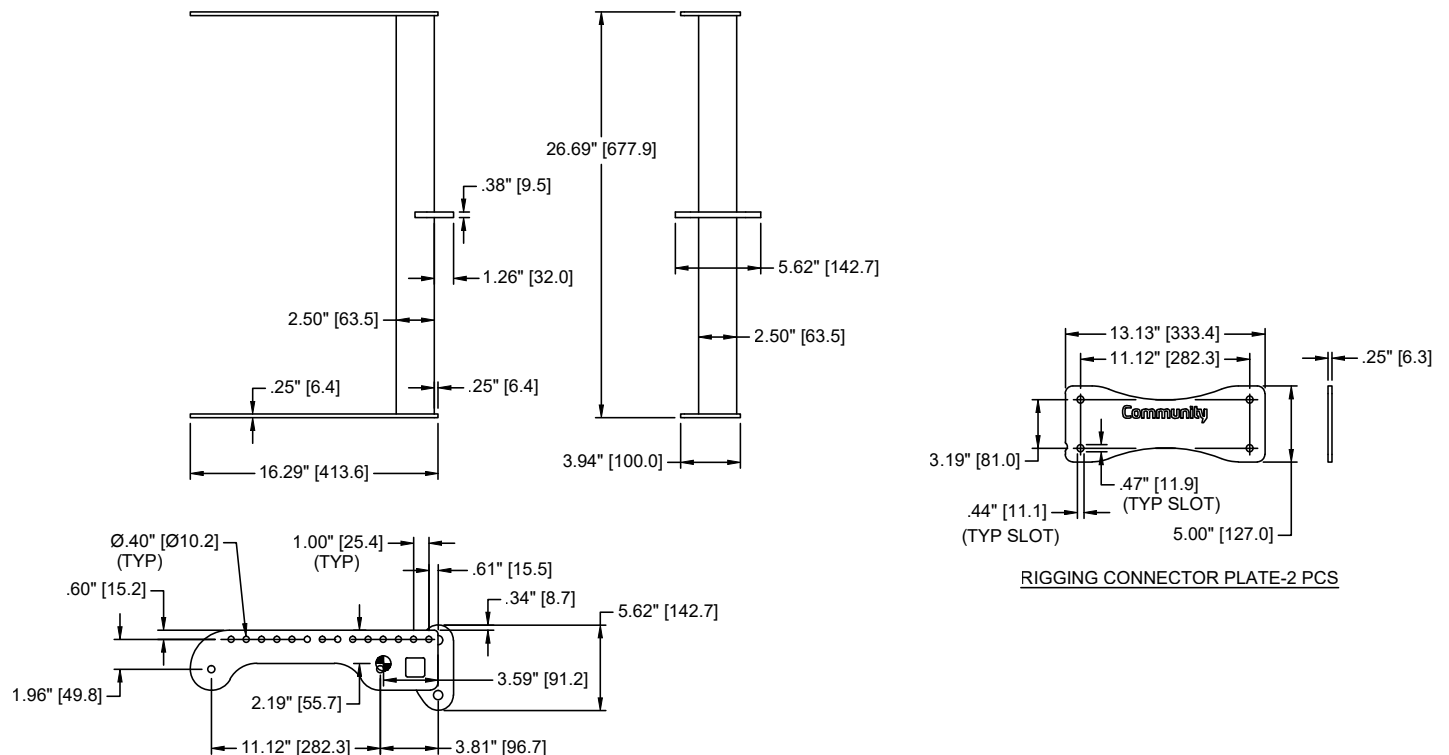

WEIGHTS

<i>LOUDSPEAKERS (includes 1 pair splay brackets)</i>	<i>Indoor [lbs (kg)]</i>	<i>Outdoor / WR [lbs (kg)]</i>
IV6-1122/05	77.3 (35.1)	62.5 (28.3)
IV6-1122/15	73.5 (33.3)	59.1 (26.8)
IV6-118S	132.9 (60.3)	99.3 (45.0)
<i>ACCESSORIES (available from Biamp)</i>	<i>Weight Indoor [lbs (kg)]</i>	<i>Working Load Limit [lbs (kg)]</i>
IV6-GP-AF	76 lbs (34.5kg)	1300 lbs (589.7 kg)
IV6-LAF-PBB	23 lbs (10.4kg)	850 lbs (385.6 kg)
IV6-SB-AF	108.0 (49.0)	2000 lbs (907.2 kg)
IV6-LAU	13.5 lbs (6.1 kg)	500 lbs (226.8 kg)
PY1-EN750-1550	6 lbs (2.7 kg)	1550 lbs (703.1 kg)

Note: Every effort has been made to insure that the information contained in this manual was complete and accurate when printed. However, due to ongoing technical advances, changes or modifications may have occurred that are not covered in this manual. The latest version is available at on the Biamp website <[here](#)>

Caution: Installation of loudspeakers should only be performed by trained and qualified personnel. It is strongly recommended that a licensed and certified professional structural engineer approve the mounting design.

ACCESSORY BRACKET REFERENCE

Available from Polar Focus

Polar Focus offers two Z-Beam brackets for use with the IV6-LAF-PBB (shown) and additional brackets for other mounting applications.

Go to Polar Focus (linearrayframes.com) for more information. The other mounting options listed below can be used with the IV6 Glidepoint™ array frame (IV6-GP-AF).

OFF THE SHELF		
1	IV6-ZB-TCK	Z-Beam and Tilt Cable Kit (for use with IV6-LAF-PBB)
2	IV6-ZB-DHB	Z-Beam "Dead Hang" Bracket (for use with IV6-LAF-PBB)
	PY1-ZBH-1550	Two Point Permanent Install Mount with Center Service Pick Point
	PY1-ZBR-1550	Self-Leveling Dual Hoist Mount
	PY1-SLH	Self-Leveling Two Point Bridle Mount (1200lbs. WLL)
	PY1-RBC-1-1100	Level, Steel I-Beam Mount
	PY1-BTP1212-1550	12" x 12" Box Truss Plate Mount
	RLP-X2-1800	Redundant Load Point
	PY0-WMV-2226-250	Wall Mount (250lbs. WLL)
	PY0-STEM	Hidden Two Point Permanent Install Through-Ceiling Mount (300lbs. WLL)
	PY0-ZBH-300	Two Point Permanent Install Mount with Center Service Pick Point (300lbs. WLL)
SEMI-CUSTOM		
		<i>User-defined dimensions required</i>
	PY1-UJEXT-POST	Custom Length Ceiling Extension Post (available from 2ft. to 16ft.)
	PY1-CBA-3	Custom Sized Mount for Level or Sloped Wood-Based Beams (500lbs. WLL)
	PY1-CBA-4	Custom Sized Mount for Rolled Wood-Based Beams (450lbs. WLL)



CONTACT US

Email: support@biamp.com or CommunitySupport@biamp.com

Web: support.biamp.com

Warranty: biamp.com/legal/warranty-information



A: 9300 S.W. Gemini Drive Beaverton, OR 97008 USA

W: www.biamp.com