

[6.92]
175.78

ELECTRICAL KNOCKOUT FOR
1/2" CONDUIT (2 PLACES)

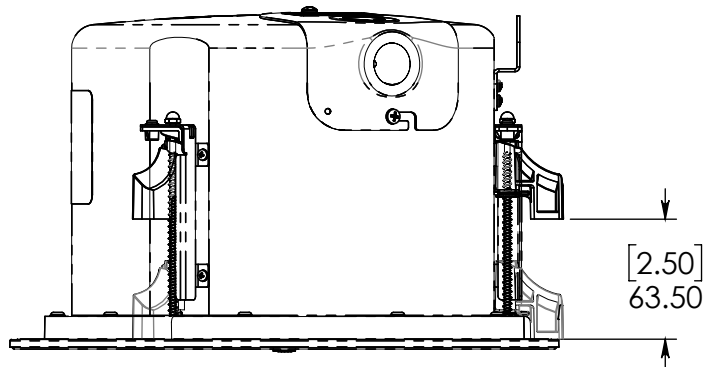

MOUNTING DOG GRIP RANGE DETAIL
(DOGS SHOWN IN MAX AND MIN POSITION)

[2.50]
63.50

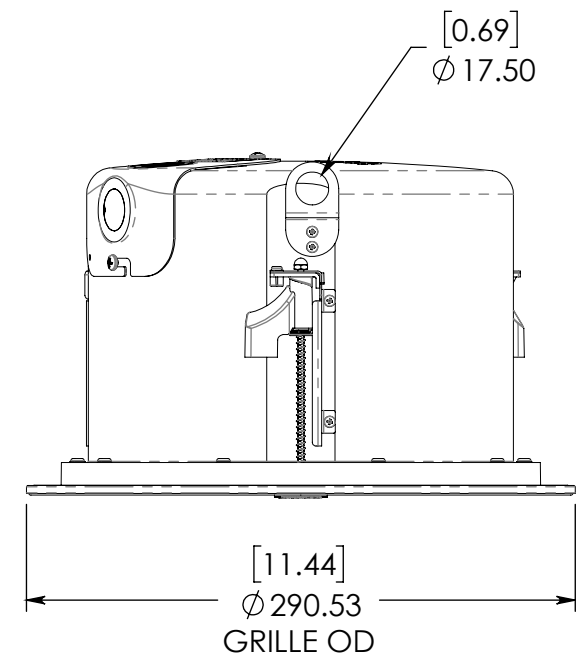

[11.44]
Ø 290.53
GRILLE OD

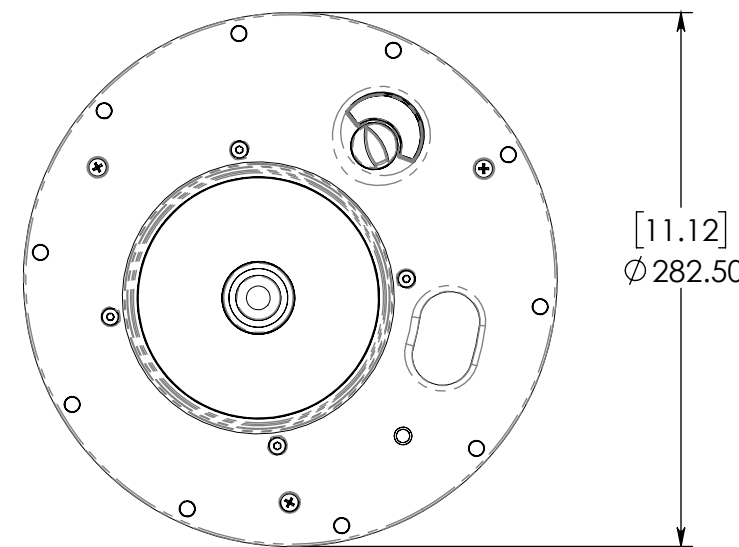

[11.12]
Ø 282.50

NOTES:
1. SPEAKER WEIGHT = 4.67KG [10.29 LBS]

MINIMUM FIRST ARTICLE REQUIREMENT
BIAMP APPROVED FAI REPORT, RoHS AND
REACH MATERIAL CONTENT DECLARATION,
BEFORE INITIAL PRODUCT SHIPMENT.

THIRD ANGLE PROJECTION

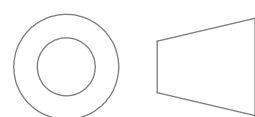

UNLESS OTHERWISE SPECIFIED:
DIMENSIONS ARE IN MM [IN]

SIZE
MATERIAL
FINISH
COLOR

PROPRIETARY AND CONFIDENTIAL
THE INFORMATION DISCLOSED HEREIN WAS
ORIGINATED BY AND IS THE PROPERTY OF
BIAMP SYSTEMS AND EXCEPT FOR THE
RIGHTS EXPRESSLY GRANTED TO THE UNITED
STATES GOVERNMENT, BIAMP SYSTEMS
RESERVES ALL PATENT, PROPRIETARY,
DESIGN USE, SALE, MANUFACTURING AND
REPRODUCTION RIGHTS THERETO.

COMMENTS:

DO NOT SCALE DRAWING

biamp.

TITLE:
DX-IC6

SIZE DWG. NO. REV

B

SCALE: 1:4 VERSION: 4 SHEET 1 OF 1