

8 7 6 5 4 3 2 1

D
C
B
A

D
C
B
A

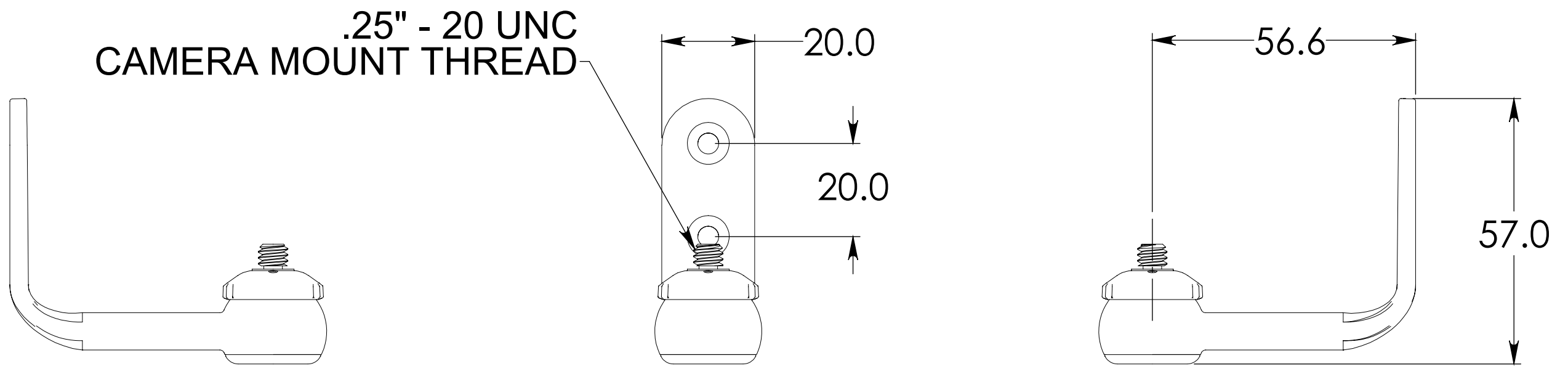

.25" - 20 UNC
CAMERA MOUNT THREAD

MINIMUM FIRST ARTICLE REQUIREMENT
BIAMP APPROVED FAI REPORT, RoHS AND REACH MATERIAL CONTENT DECLARATION, BEFORE INITIAL PRODUCT SHIPMENT.

THIRD ANGLE PROJECTION

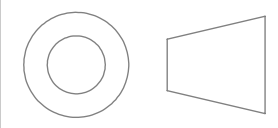

UNLESS OTHERWISE SPECIFIED:	
DIMENSIONS ARE IN MM [IN]	
TOLERANCES:	
ANGULAR:	± 1 °
ONE PLACE DECIMAL	± 0.5
TWO PLACE DECIMAL	± 0.25
THREE PLACE DECIMAL	± 0.100
UN-DIMENSIONED 3D DATA	± 0.15
SIZE	.25" - 20
MATERIAL	
FINISH	
COLOR	

PROPRIETARY AND CONFIDENTIAL
THE INFORMATION DISCLOSED HEREIN WAS ORIGINATED BY AND IS THE PROPERTY OF BIAMP SYSTEMS AND EXCEPT FOR THE RIGHTS EXPRESSLY GRANTED TO THE UNITED STATES GOVERNMENT, BIAMP SYSTEMS RESERVES ALL PATENT, PROPRIETARY, DESIGN USE, SALE, MANUFACTURING AND REPRODUCTION RIGHTS THERETO.

COMMENTS:

DO NOT SCALE DRAWING

biamp.		
TITLE: .25" - 20 CAMERA WALL MOUNT		
SIZE B	DWG. NO.	REV
SCALE: 1:1	VERSION: 5	SHEET 1 OF 1

8 7 6 5 4 3 2 1